

6

7-7-76
OBSOLETE
11/14/76

Important

For Your Own Safety
 Before Assembling and Operating
 This Unit, Read This Operator's
 Manual Carefully and Completely.
 Learn The Operation, Applications
 and Potential Hazards Peculiar To
 This Unit.

RIDGID

400 Power Drive

Operator's Manual
and Parts List

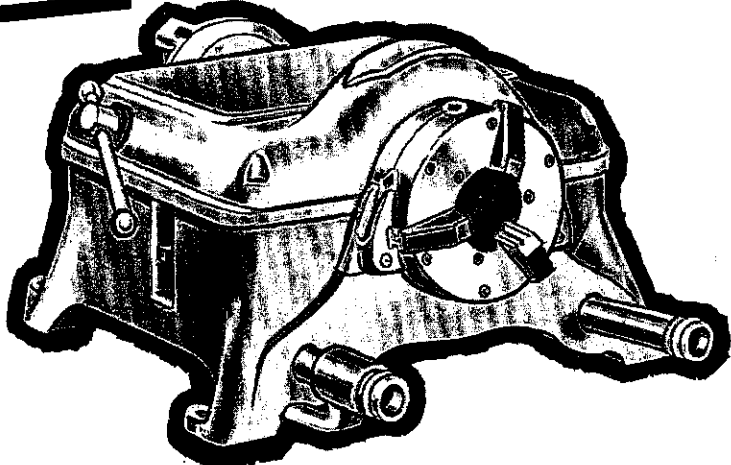

RIDGID®

**Pre-Tested
Work Saver Tools**

The Ridge Tool Company

400 Clark St., Elyria, Ohio 44035, U.S.A.

Contents

	Page
Guarantee	1
Specifications	2
Safety	2-A
To Thread, Ream and Cut Pipe	3
Threading 2½" to 12" Pipe	4
400 Power Drive Cover & Base Parts Serial No. 701 and Up	5
400 Drive Shaft Assembly Serial No. 15, 578 ... and Up	6
Motor Parts For 1157 & 2357 Motors	7
To Assemble 400 Power Drive Stands	8
Parts For No. 1 Speed Grip Chuck Adaptor	9
Service and Performance	11

The Ridge Tool Company

400 Clark St., Elyria, Ohio 44035, U.S.A.

Printed in U.S.A.

For Your Own Safety

This unit is equipped with a Foot Switch which turns it on and off.

The switch on the side of the unit determines only the direction of chuck rotation.

Instructions and illustrations in the attached operator's manual are applicable, however, they do not include information on the Foot Switch.

The Foot Switch is for your convenience and safety.

If your present RIDGID Power Drives or Pipe and Bolt Threading Machines are not equipped with Foot Switches, we recommend the RIDGID No. 301 Foot Switch. You will enjoy the convenience as well as the added safety.

This Wiring Diagram supersedes the present Wiring Diagram in this operator's manual.

This unit is wired for A.C. only.

Note: This wiring diagram is typical of 400, 400A, 500 and 535 Machines.

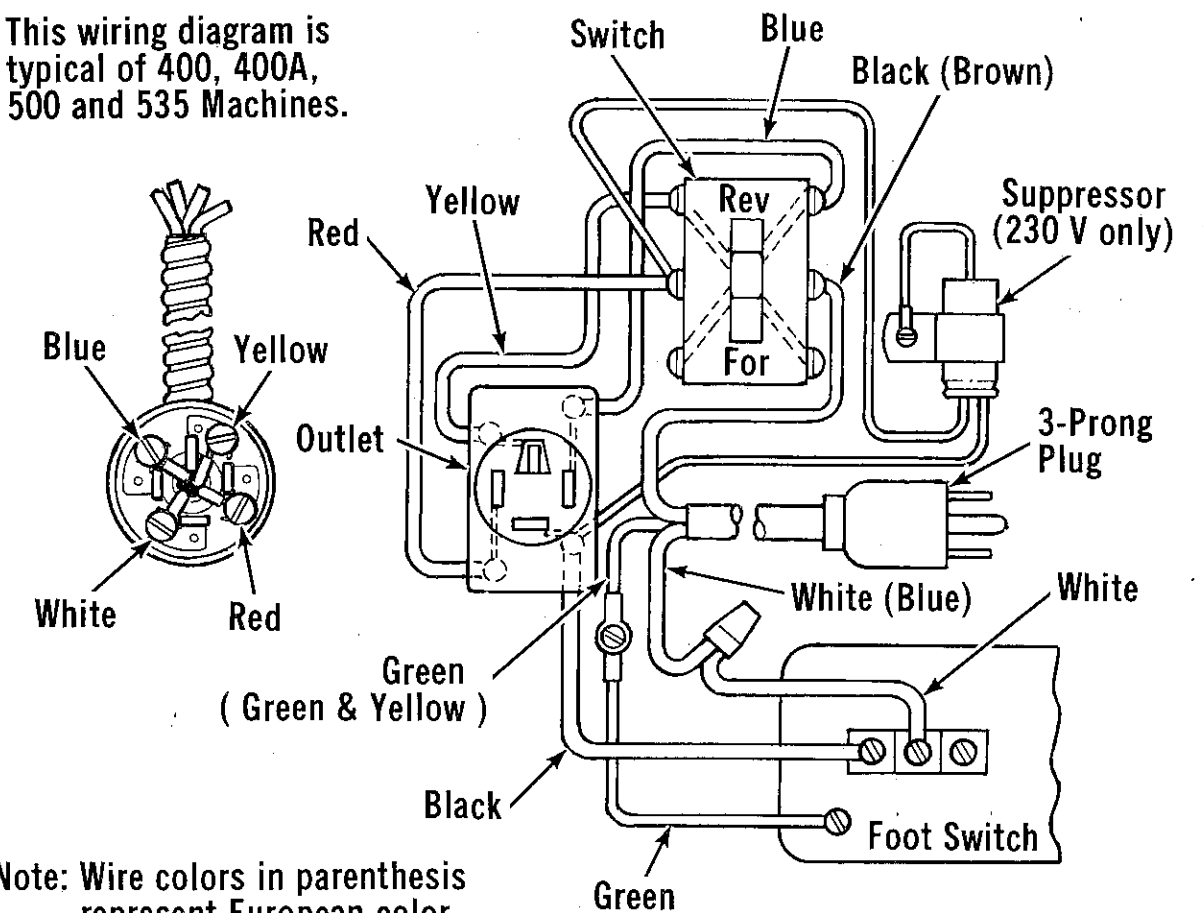

Note: Wire colors in parenthesis represent European color code. European cord the same except for plug.

RIDGID

Pre-Tested Work Saver Tools

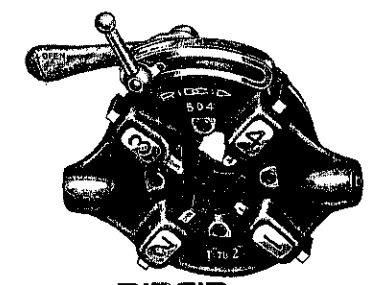
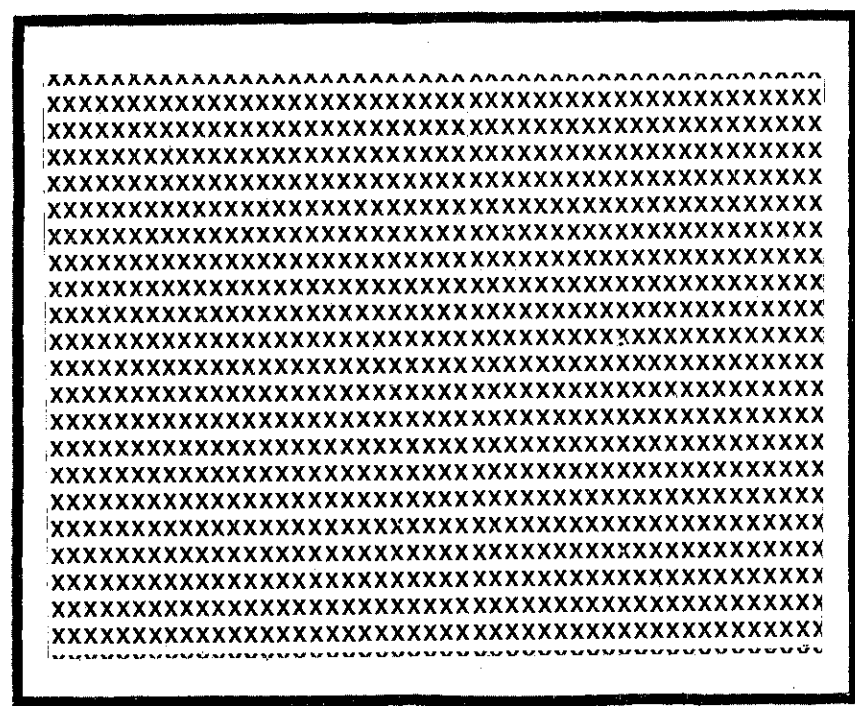

RIDGID
502 & 504 Q.O. Threader

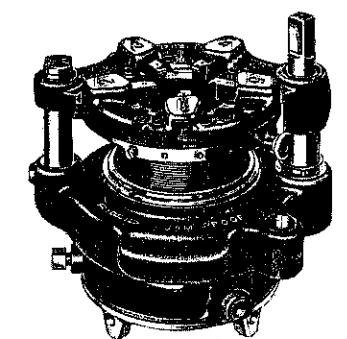

RIDGID
141 Jam-Proof Threader

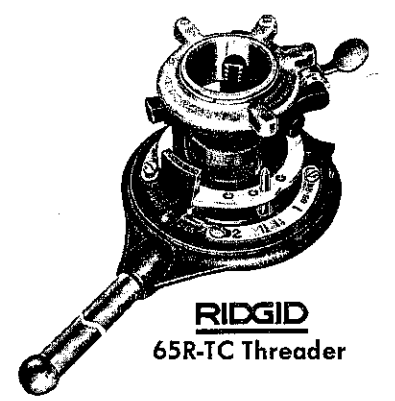

RIDGID
65R-TC Threader

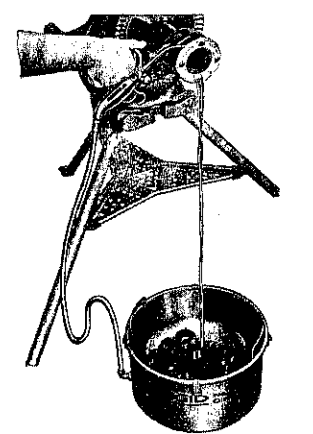

RIDGID NO. 318
Oiler



RIDGID Universal Drive Shaft

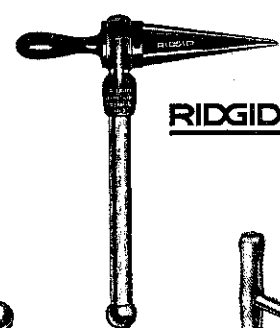

RIDGID No. 2 Reamer

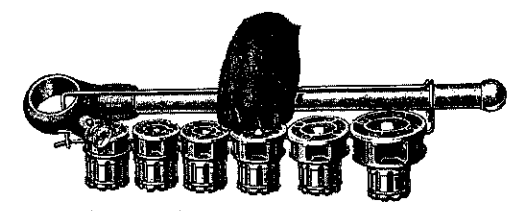

RIDGID Drop Head Threaders

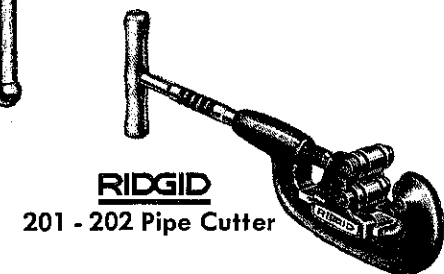

RIDGID
201 - 202 Pipe Cutter

RIDGID 400

Portable Power Drive

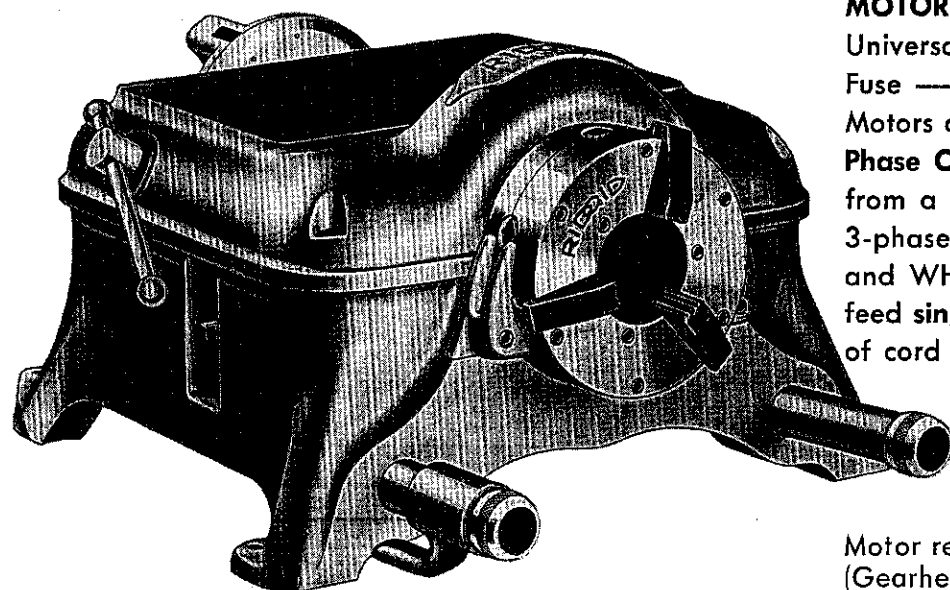

No. "400" Portable
Power Drive

CAPACITY — 1/8" to 2" Pipe and Conduit; 1/4" to 2" Bolts and Rod. 2-1/2" to 12" Pipe with RIDGID Universal Drive Shaft and Geared Tools.

Specifications

MOTOR — regularly furnished — 1/2 H.P. — Universal — 115 Volt A.C. or D.C. 30 Amp. Fuse — 15-ft. oil resistant cord. (230 Volt Motors can be furnished upon request — **Single Phase Only.**) 230 Volt Motor can be operated from a 3-phase line by customer attaching his 3-phase plug to cord and connecting **BLACK** and **WHITE** wire of cord to prongs of plug to feed **single phase** current to motor. **Green** wire of cord is ground wire.

Motor reduction gears with sealed in lubrication, (Gearhead Grease) . . . are completely enclosed, protecting them against any foreign matter. Bronze bearings in Power Drive base, for main shaft are pressure greased; and driving gears are coated with lubricating grease.

SWITCH — Forward — Stop — Reverse.

BENCH MOUNTING — Place RIDGID "400" Power Drive on a solid bench in desired position and bolt securely with 3/8" bolts at each foot.

Shipping Weights

Power Drive only and 1 gal.	
RIDGID thread cutting oil	152 lbs.
Wheel Stand — "Kit A"	59 lbs.
Leg and Tray Stand — "Kit C"	31 lbs.

"400" available with convenient wheel stand for converting bench model to handy open wheel stand. Front legs have handles that swing in, out of way when not in use.

"Kit A"

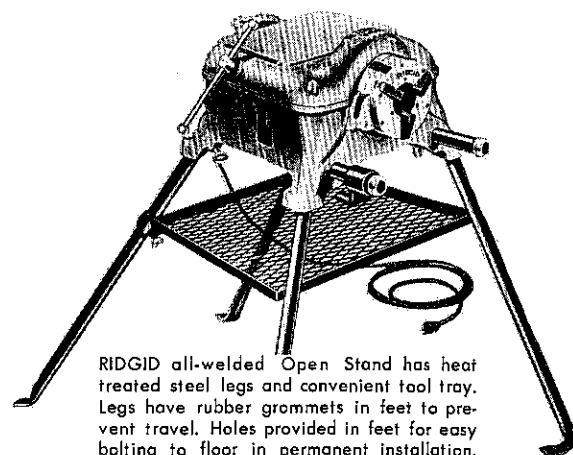

RIDGID all-welded Open Stand has heat treated steel legs and convenient tool tray. Legs have rubber grommets in feet to prevent travel. Holes provided in feet for easy bolting to floor in permanent installation.

"Kit C"



PRINTED IN U.S.A.

The Ridge Tool Co., Elyria, Ohio, U.S.A.

Safety

- 1. Know your machine.** Read the Operator's Manual carefully. Learn the operation, application, and limitations as well as the specific potential hazards peculiar to this machine.
- 2. Avoid accidental starting.** Make sure switch is off (center position) before plugging in power cord.
- 3. Ground the machine.** For safety, this machine is equipped with a power cord having a three-prong plug for grounding. Make sure the electrical outlet being used is grounded within the electrical system. If outlet is not grounded, a wire should be run from E-3467 Ground Screw provided on outside of base of machine to a known ground. (Water pipe or pipe driven into ground as examples.)
- 4. Keep guards in place** and in working order.
- 5. Remove adjusting keys and wrenches.** Form habit of checking to see that keys and adjusting wrenches are removed from machine before turning on machine.
- 6. Support work.** Support long, heavy work from the floor with a pipe support.
- 7. Secure work, machine and accessories.** Carefully tighten chuck (and rear centering device if work is sufficiently long) on work. Make sure machine, and stand if used, are stable.
- 8. Wear proper apparel.** No loose clothing (unbuttoned jackets or loose sleeve cuffs) or jewelry to get caught in moving parts.

- 9. Don't overreach.** Keep your proper footing and balance at all times. Be sure you can reach switch safely at all times. Do not reach across moving or rotating parts or material being worked on. Keep hands and loose tools away from moving elements.
- 10. Maintain machine** in top condition. Use sharp cutting tools and keep machine clean for best and safest performance. Follow lubricating instructions.
- 11. Keep work area clean.** Cluttered areas, benches, and slippery floors invite accidents.
- 12. Avoid dangerous environment.** Don't use the machine in damp or wet locations. Keep work area well illuminated. Allow sufficient space to operate machine and accessories properly and for others to pass safely.
- 13. Wear ear protection** if exposed to long periods of very noisy shop operations.
- 14. Use safety glasses and footwear.**
- 15. Keep visitors away.** All visitors should be kept a safe distance from work area.
- 16. Don't force machine.** It will do the job better and be safer at the rate for which it was designed.
- 17. Use recommended accessories.** Consult the Operator's Manual. Use of improper accessories may be hazardous.
- 18. Disconnect power cord** before adjusting and servicing, and before changing accessories. Cord should be in good condition.

The Ridge Tool Co., Elyria, Ohio, U.S.A.

PRINTED IN U.S.A.

To Thread, Cut and Ream with the "400"

POWER DRIVE with Hand Tools

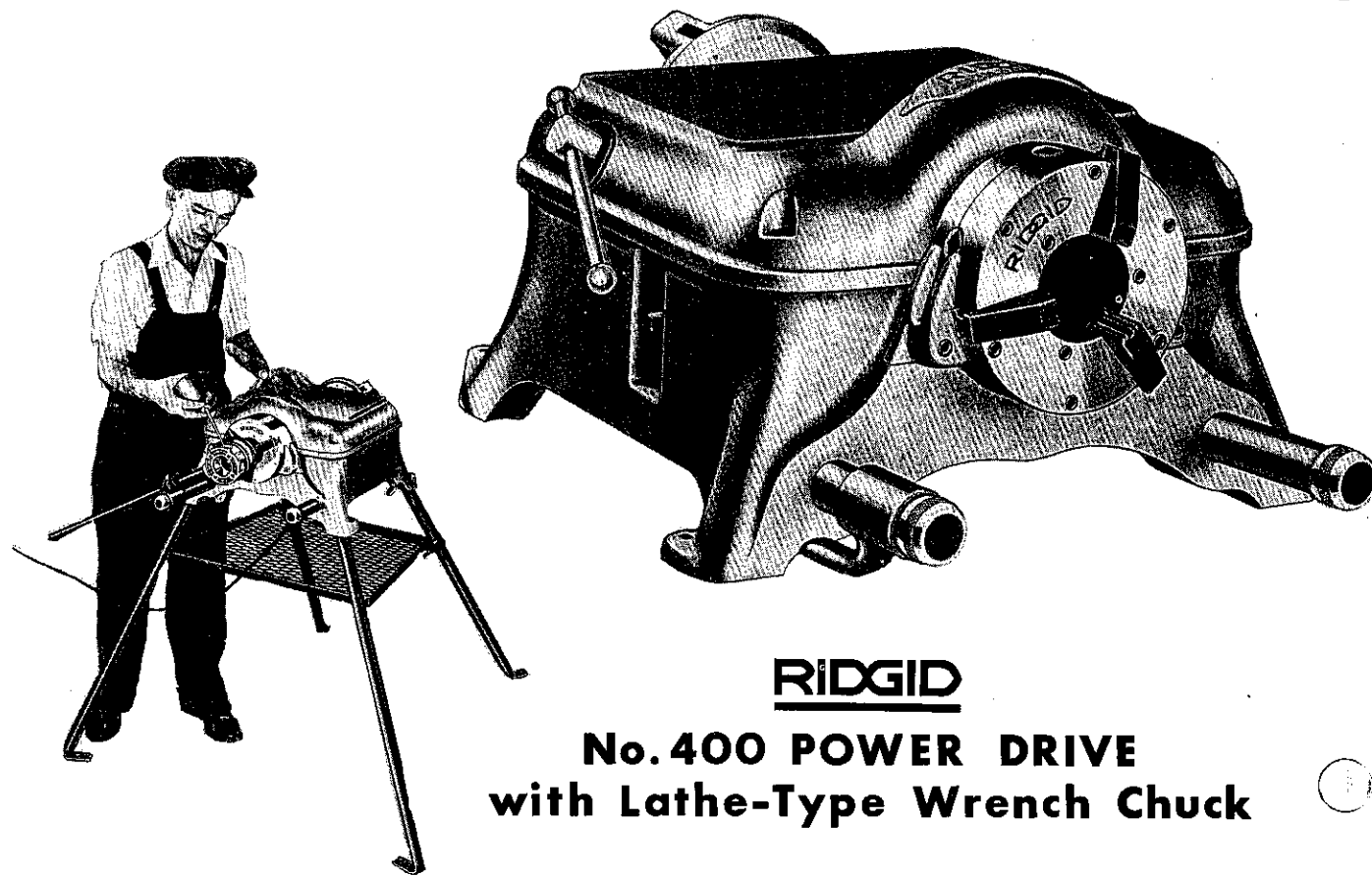

RIDGID No. 400 POWER DRIVE with Lathe-Type Wrench Chuck

TO THREAD PIPE

1. Insert pipe to be threaded into Power Drive at either front or rear end. Let pipe extend out of chuck far enough for threader to clear chuck while threading.
2. First center pipe and tighten chuck jaws with a moderate twist of the chuck wrench. If the pipe extends out the back of the Power Drive, close the rear self-centering workholder jaws.
3. Place threader on pipe in usual way. Pull out tool support bar to desired position and allow threader handle to rest on tool support bar on switch side. Hook safety latch over handle.

You are now ready for threading. Turn on switch. It is important that you use plenty of RIDGID thread cutting oil — a high grade, sulphur lard threading and cutting oil — Dark or Nu-Clear.

TO THREAD BOLTS OR CONDUIT

1. Operation is the same as in threading pipe except that you use your bolt or conduit threader.

TO CUT PIPE

1. Insert pipe into "400" and tighten chuck jaws and rear centering device the same as for threading.
2. Put tool support bar in position to support cutter handle. Apply cutter to pipe just as you would if cutting by hand. Let cutter handle rest on tool support bar. Tighten cutter blade to contact with pipe. Turn Power Drive switch to FORWARD, then continue turning cutter blade into pipe until cut is completed.

TO REAM PIPE

1. After pipe is threaded, place your reamer in pipe end, let handle of reamer rest against tool support bar. Turn on motor. Press reamer into pipe as needed to remove burr.

Operating Instructions for **RIDGID** Jam-Proof Geared Threaders For Pipe and Conduit

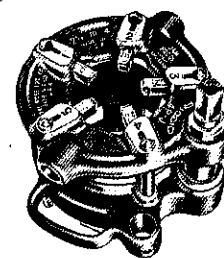

No. 4PJ — 2½" to 4" Jam Proof Geared Threader

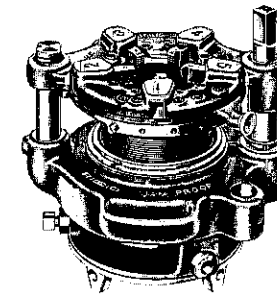

No. 141 — 2½" to 4" Jam Proof Geared Threader

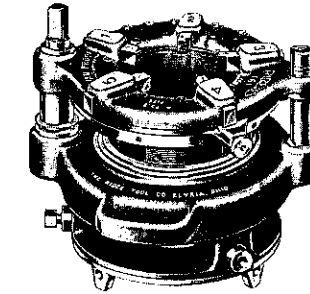

No. 161 — 4" to 6" Jam Proof Geared Threader

RIDGID Close Coupled Method

1. Place geared threader on floor or workbench with the Drive Shaft up.
2. Place 844 Drive Bar on Drive Shaft of threader and tighten the two set screws in Drive Bar head.

3. Insert Drive Bar into the chuck of your RIDGID Power Drive.
4. Tighten the jaws of the Power Drive chuck into the three "V" shaped notches in the head of 844 Drive Bar.
5. Close Rear Centering Device on the Shaft of 844 Drive Bar.

Figure 1.

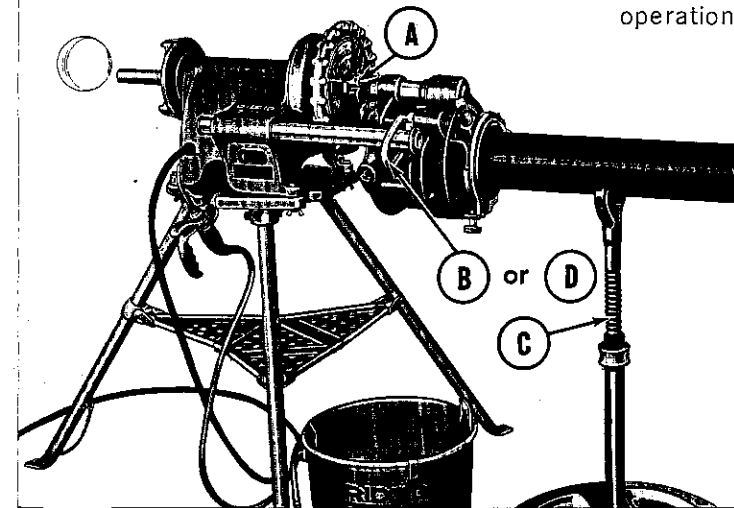

To thread with a No. 4PJ and 141 Threaders and 200, 300, 400, or 400A RIDGID Power Drive, equipment (A, B, C) must be used. For operation set-up see Figure 1, at left, with a 300 Power Drive.

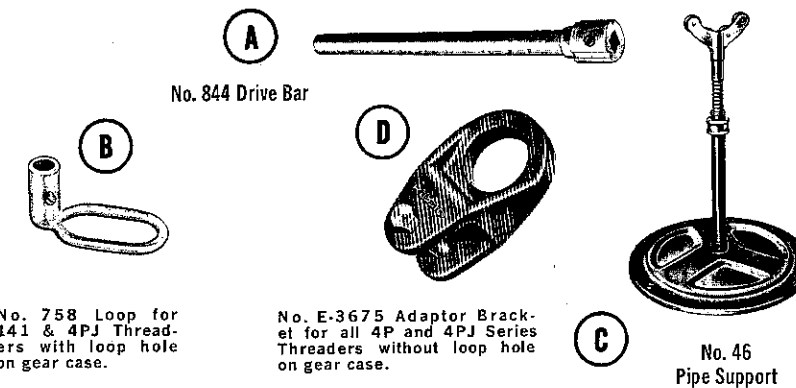
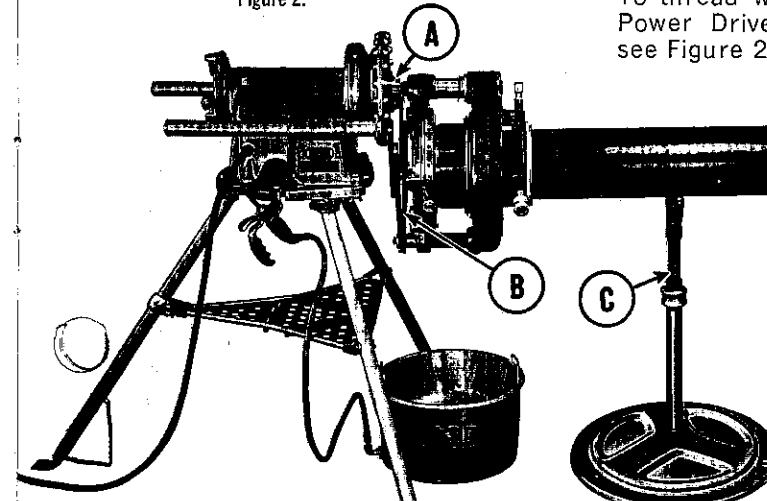
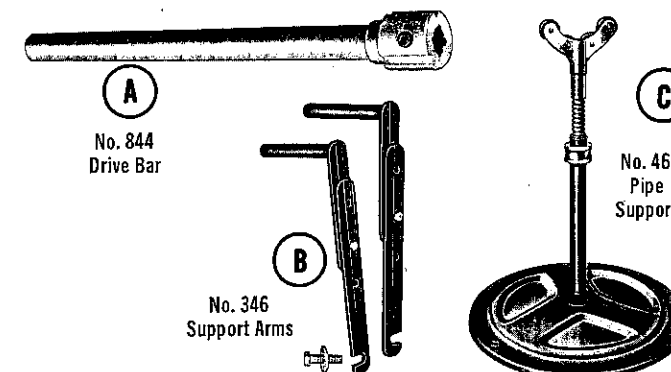

Figure 2.



To thread with a No. 161 threader and 200, 300, 400, or 400A RIDGID Power Drive, equipment (A, B, C) must be used. For operation set-up see Figure 2, at left, with a 300 Power Drive.



Threading with RIDGID Universal Drive Shaft

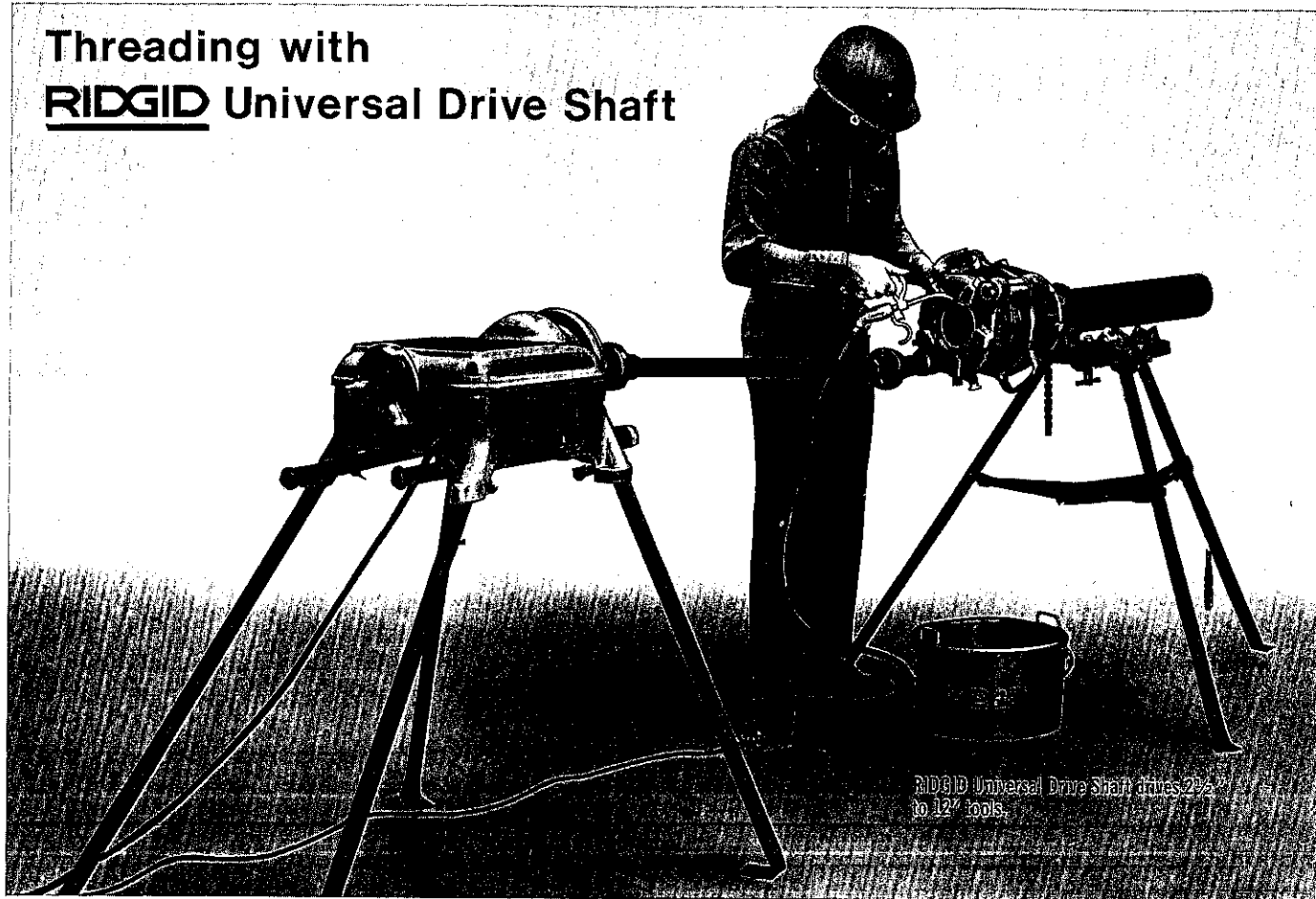

RIDGID Universal Drive Shaft drives 2 1/2" to 12" tools.

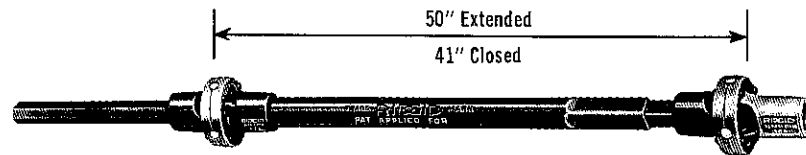

Threading with RIDGID No. 840 Universal Drive Shaft

This operation will require a RIDGID Universal Drive Shaft, Foot Switch, Geared Threader, a Vise Stand capable of holding the size pipe desired and a Power Drive. When threading pipe larger than 2", the Power Drive and Vise Stand must be securely anchored or provisions should be made to make sure the Power Drive and Vise Stand are stable. Be sure the Vise Stand is in line, on the same level and approximately the length of the Universal Drive Shaft away from the front chuck of the Power Drive.

Slide long hexagon end of the Universal Drive Shaft into front chuck of Power Drive. Tighten chuck and rear centering device.

Fasten pipe securely in vise on Vise Stand. Long pieces of pipe may have to be supported with a RIDGID No. 92 Pipe Support.

Slide Threader on pipe and carefully center end of pipe in throats of dies. Tighten workholder clamp screw must be tightened **Securely**.

Slip square socket of Universal Drive Shaft over square end of Threader drive shaft and tighten set screws. When properly positioned, sliding shank of Universal Drive Shaft should neither be fully extended nor fully closed. You are now ready to thread.

Plug Power Drive cord into Foot Switch cord and then plug Foot Switch cord into grounded outlet. Put Power Drive switch in FOR (forward) position. Locate Foot Switch as shown above. To start Power Drive use Foot Switch.

During threading operation, use RIDGID Thread Cutting Oil freely. When changing setup or dismantling operation, always unplug power cord.

SPECIFY "400" POWER DRIVE SERIAL NUMBER WHEN ORDERING PARTS.

PRINTED IN U.S.A.

The Ridge Tool Co.,
Elyria, Ohio, U.S.A.

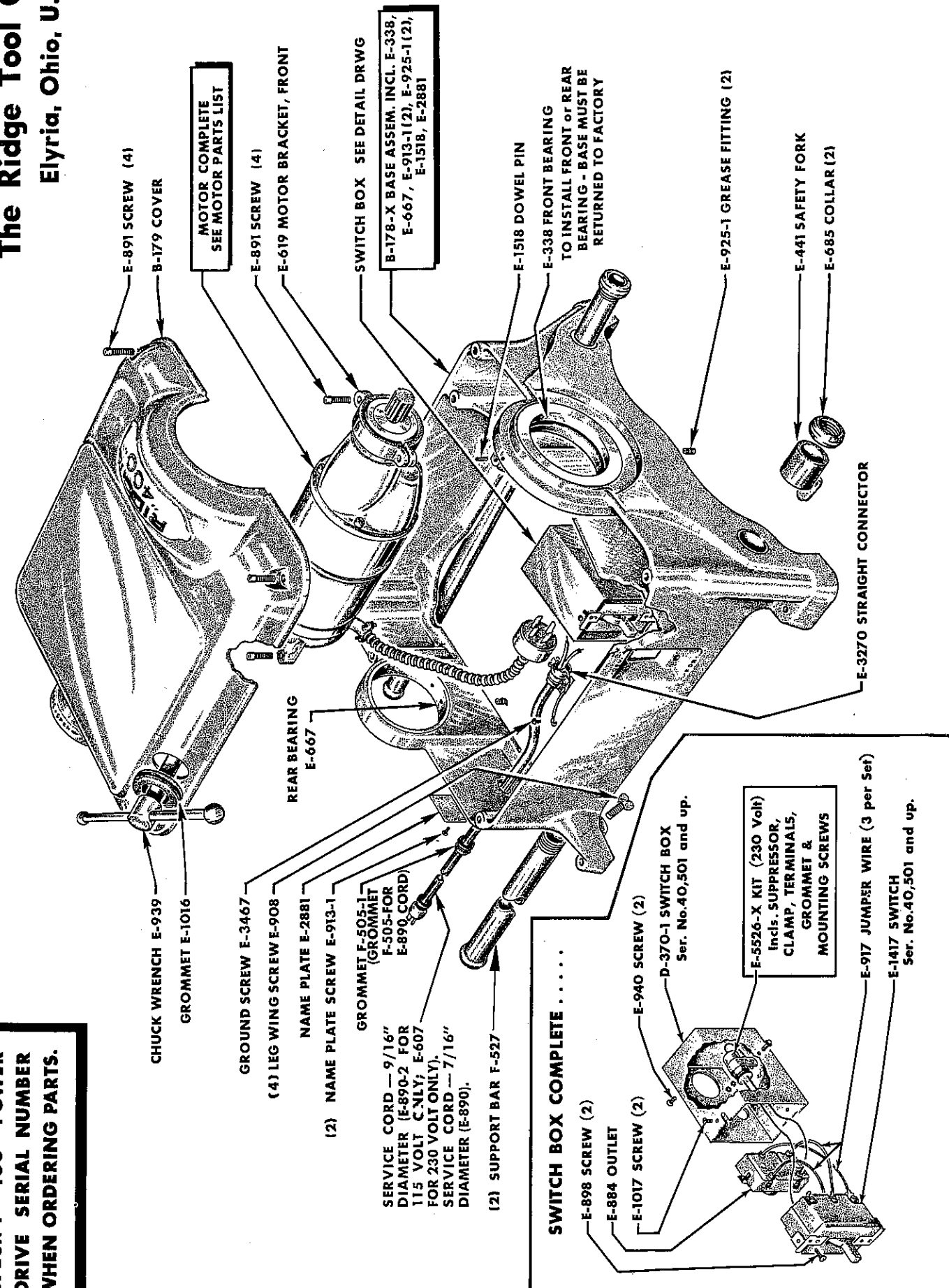

Drive Shaft for "400" Power Drive Serial No. 15,578 and Up.

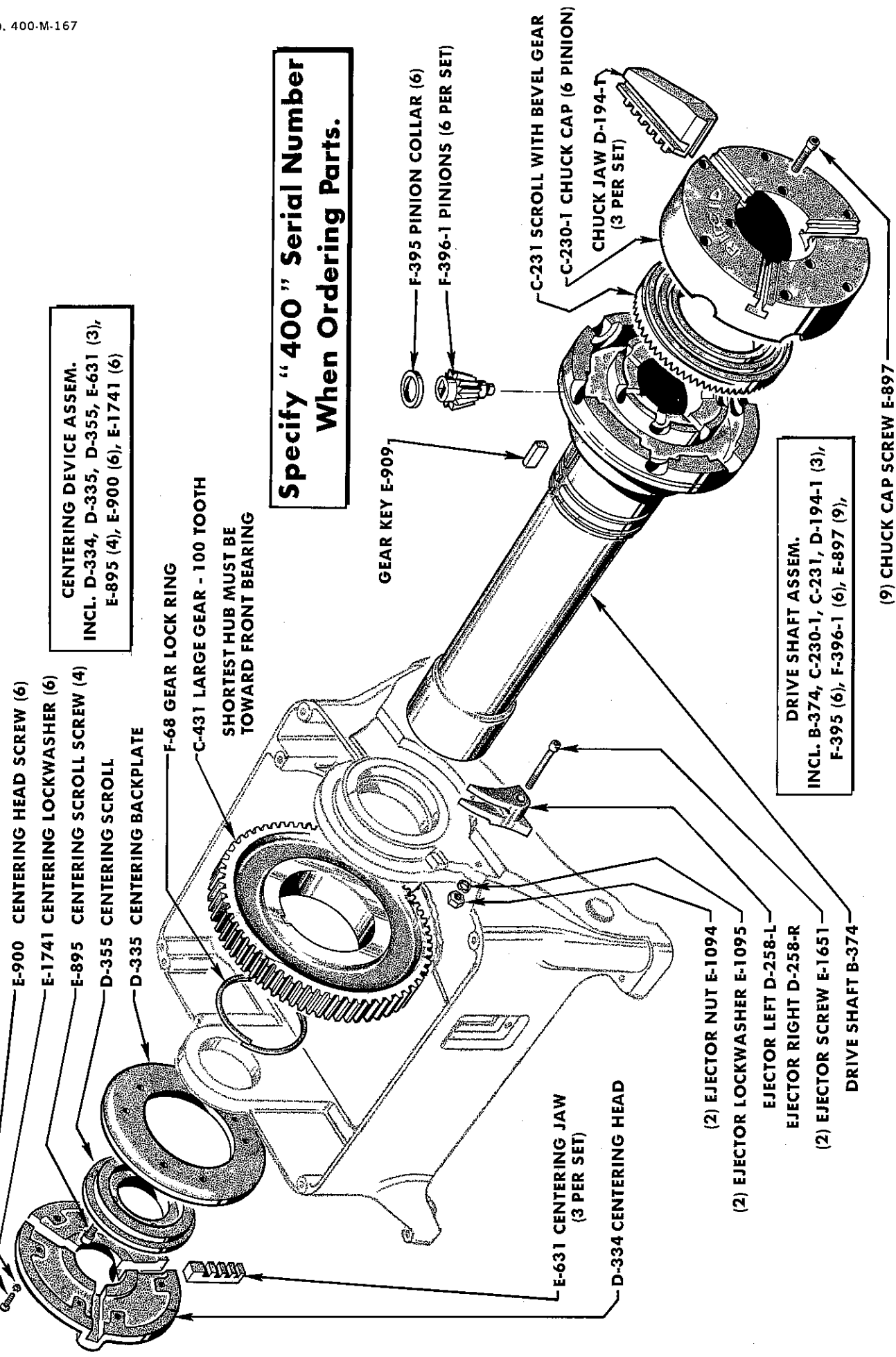

The Ridge Tool Co., Elyria, Ohio, U.S.A.

POWER DRIVE WITH WRENCH-TYPE CHUCK

Printed in U.S.A.

The Ridge Tool Co. Elyria, Ohio, U.S.A.

D-1015 GEAR HEAD ASSEMBLY
Incls.
B-824 Gear Housing
E-1721 Locknut (2)
E-2596 Pinion (10 Tooth)
E-2597 Gear (48 Tooth)
E-2600-X 1ST INTERMEDIATE
GEAR ASSEMBLY
E-2601-X 2ND INTERMEDIATE
GEAR ASSEMBLY
E-2603-X Lock Screw Assembly
E-2604 Main Drive Gear Key
E-2610 Main Drive Gear Washer
E-2616-X 1 Set Roller Bearings

NOTE: On Machines with
Serial Nos. 42,401 to 43,101
Lead Wire (E-2861) was Black.

Standard Motor Illustrated
(36 R.P.M. chuck speed).
Other RIDGID Motors
available for chuck speeds
of 54,72, or 102 R.P.M.

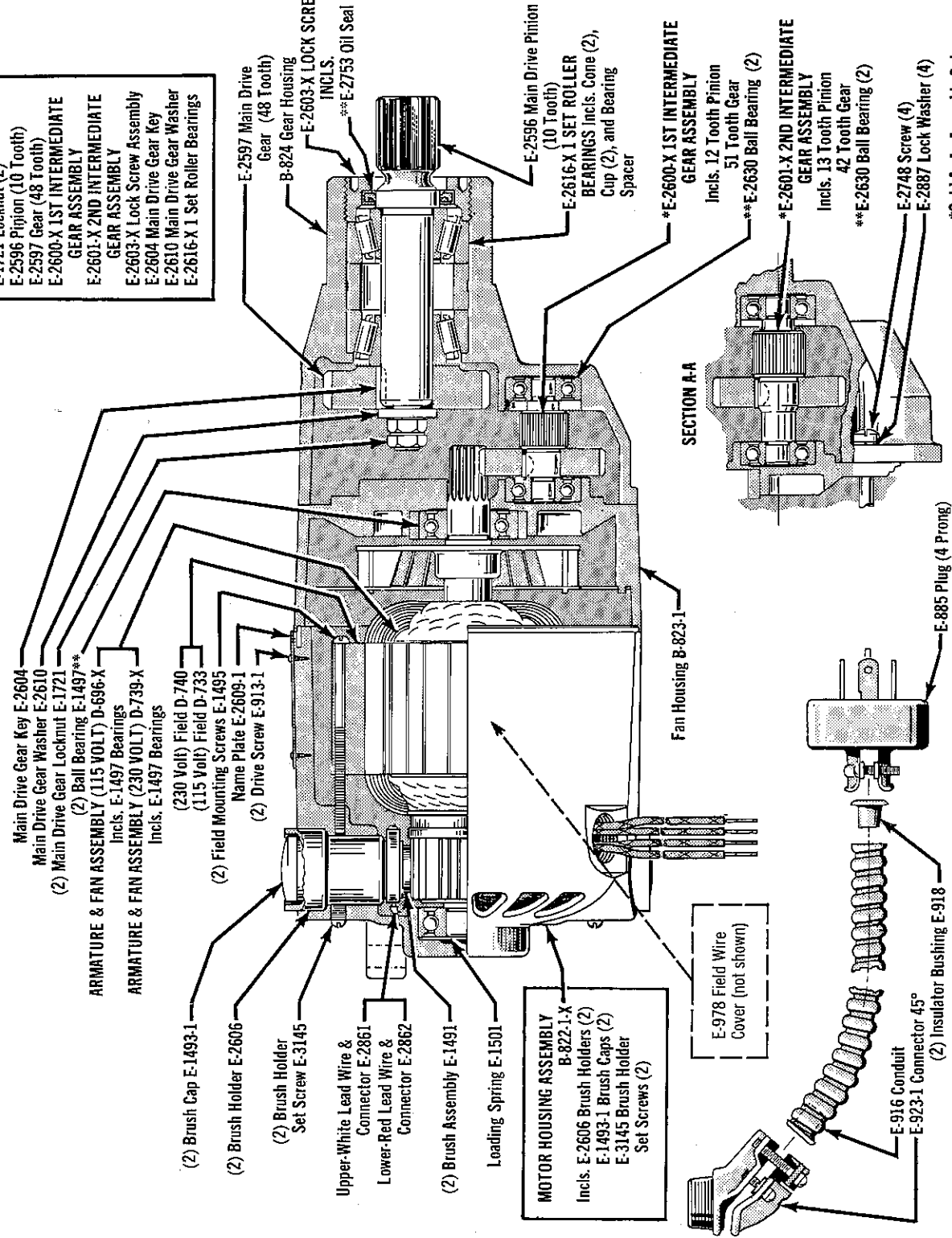

**Specify Motor Model
No. and Power
Drive Serial No.
when Ordering
Parts**

*Sold As An Assembly Only
***Can Be Purchased Separately

RIDGID Motors
for 400 Power Drives

Model No. 1157 (115 Volt) Serial Nos. 42,401 To 42,900 & 42,926 To 49,000
Model No. 2357 (230 Volt) Serial Nos. 49,001 and up.

To Assemble Legs, Wheels and Tray

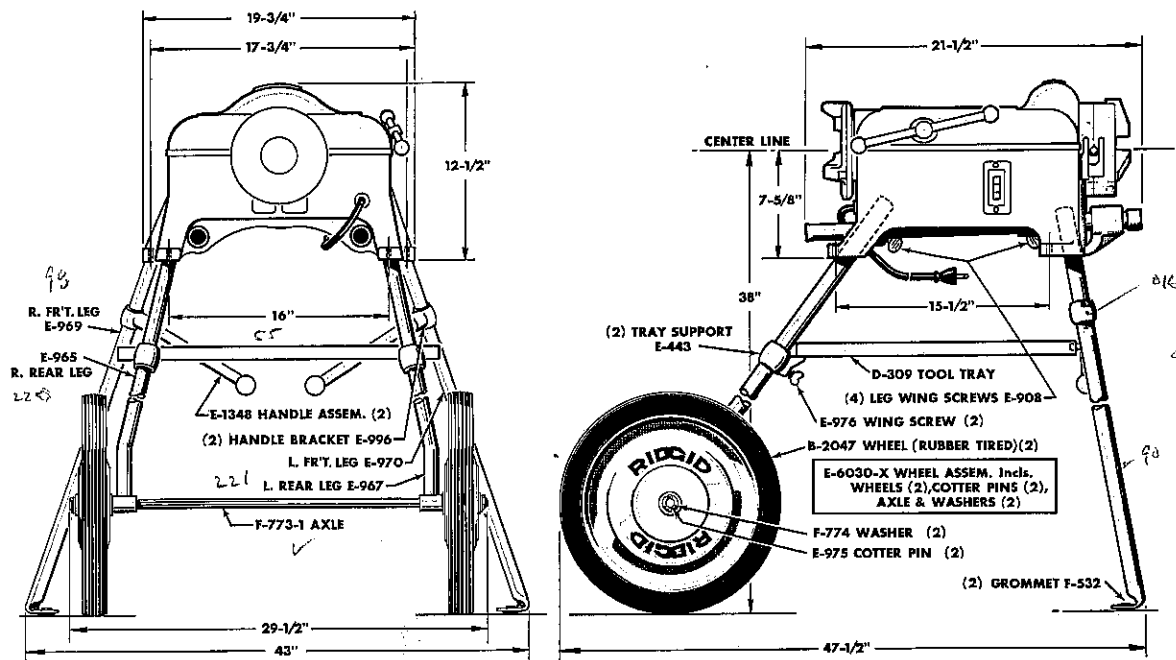

Wheel Type

1. Insert front legs into Power Drive Base. Front legs have small posts to support tray (D-309). The lower posts must face toward the rear legs. Tighten wingnuts (E-908).
2. Insert rear legs with the bends as shown. Making sure hubs are in a straight line for the axle. Tighten wingnuts.

3. Slide axle thru both hubs. Add wheels, A washer outside each wheel, and cotter pins.
4. Insert tray (D-309) by engaging holes on front leg posts as shown. Adjust the supports (E-443 and slide up as far as possible. Tighten wingnuts (E-976).
5. Thread handles (E-1348) into brackets (E-996).

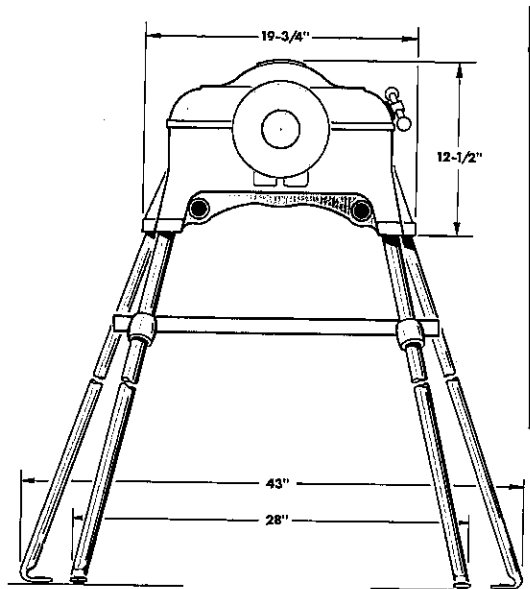

KIT C—
Stand and tray assembly for 400 Power Drive. (Front legs; rear legs; tray and fittings.)

KIT A—
Wheel stand with tray for 400 Power Drive. (Front legs; rear legs; tray; handles; axle; wheels and fittings.)

KIT B—
Converts stand type to wheel type. (Rear legs; wheels; axle; fittings and handles.) Uses front legs and tray of your stand type.

For stand replacement parts order by part number.

Stand Type

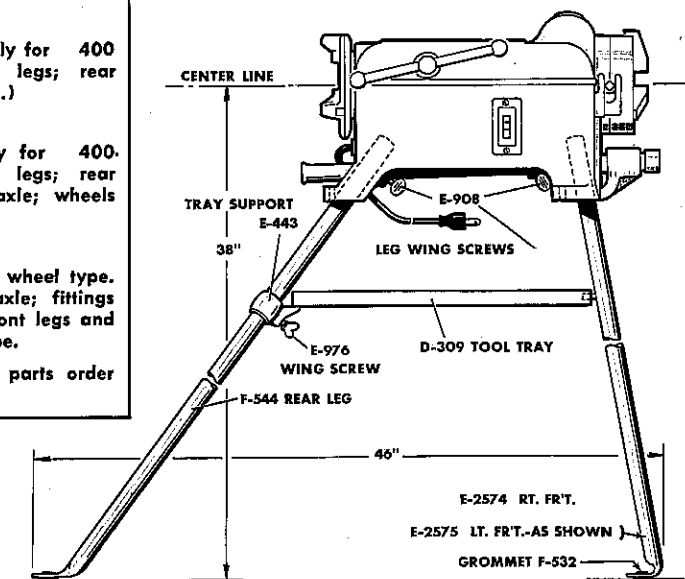

1. Insert front legs into power drive base. Front legs (E-2574 right. E-2575 left) have small posts which support tray (D-309). These must face toward the rear legs.

2. The feet on rear (F-544) should toe back, as shown. Tighten wingnuts (E-908).
3. Insert tray by engaging holes in tray onto front leg posts as shown. Adjust supports (E-443) and slide up as far as possible. Tighten wingnuts (E-976).

The Ridge Tool Co.
Elyria, Ohio, U.S.A.

The Ridge Tool Co.
Elyria, Ohio U.S.A.

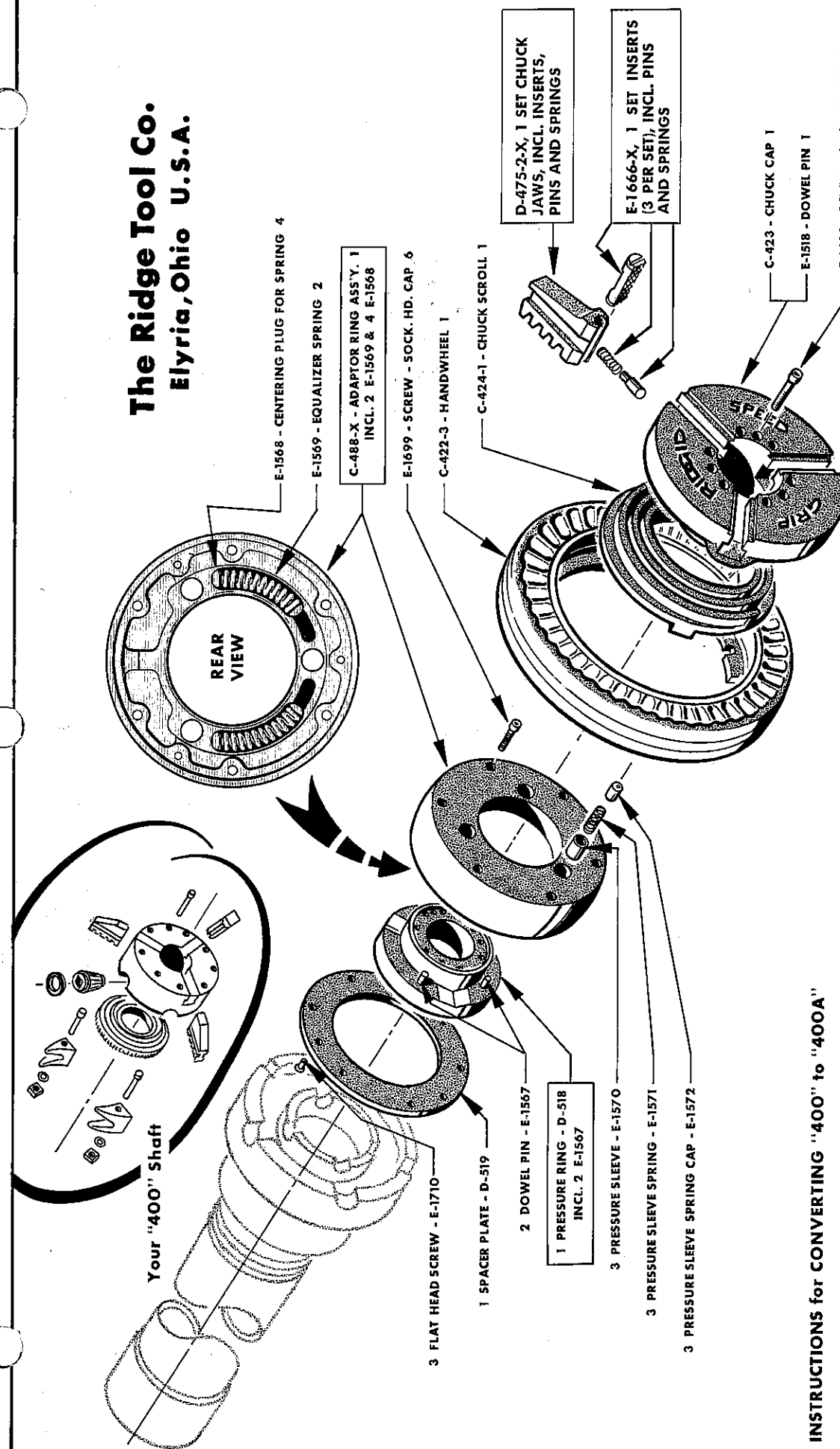

IMPORTANT
When ordering parts, be sure to give serial number of your machine, part number & name.

INSTRUCTIONS for CONVERTING "400" to "400A"
FIRST REMOVE THE PARTS ENCIRCLED ABOVE FROM YOUR DRIVESHAFT...

To Install The No. 1 Speed Grip Adapter

1. Remove (9) E-1429 Cap Screws and separate the assembly of C-422-3 Handwheel, C-424-1 Scroll and C-423 Chuck Cap from the rest of the unit without disturbing E-1572 Caps.
2. Assemble the remaining parts to your Driveshaft, using (6) E-1699 Cap Screws. When the E-1570 Pressure Sleeves (not E-1572 Caps) are flush with the face of the C-488 Adaptor Ring, they are in the correct position.
3. Now replace the assembled Handwheel, Scroll and Chuck Cap using E-1518 Dowel for proper alignment. (Chuck Jaws are already assembled in the Cap) Numbers stamped on Chuck Jaws must correspond with numbers stamped on Chuck Cap.

RIDGID No 1 Speed Grip Chuck Adaptor for "400" Power Drive

FOR BEST SERVICE AND PERFORMANCE

Simplicity of design and operation have made the RIDGID 400 Power Drive so easy to use that very few instructions are necessary.

1. As a safety factor, always remove chuck wrench even though there is an automatic ejector.
2. Use sharp dies at all times — it pays. Dull dies require more power from motor.
3. Flood dies with RIDGID Thread Cutting Oil, a high grade sulphur-and-lard base cutting oil.
4. For supporting long lengths of pipe, use a RIDGID quick-adjusting Pipe Support Stand.
5. Grease main shaft bearings every six months or oftener if Power Drive is subject to hard usage. (2 grease fittings on underside of base; 1 at each end of shaft). Use a good grade of cup grease.
6. RIDGID 400 Power Drives are furnished with 115 volt motors. (230 volt motors available upon request — single phase only). 230 volt motor can be operated from a 3-phase line by customer attaching his 3-phase plug to cord and connecting black and white wire of cord to prongs of plug to feed single-phase current to motor. Green wire of cord is ground wire.
7. Plug cord into any outlet which carries the same voltage as the motor. (See nameplate on motor). Be sure motor and power supply are both the same. Plug and 15 feet of oil resistant cord furnished; if you add cord, use 12-gage wire; if 100 feet or more is added, use 10 gage. Using smaller gage wires will cause voltage drop to motor and power drive will not operate efficiently.
8. Use only 30 ampere fuses.
9. Inspect motor brushes regularly and replace when worn.
10. Round post of cord plug is the ground wire. (Green wire of cord).
11. To remove motor: pull 4-pronged plug from switch box in power drive — remove 4 screws holding motor and lift motor and bracket out. There are no wires to disconnect or connect. Only one way to insert motor plug.

DIAGRAM SERIAL No. 25922 to 43100

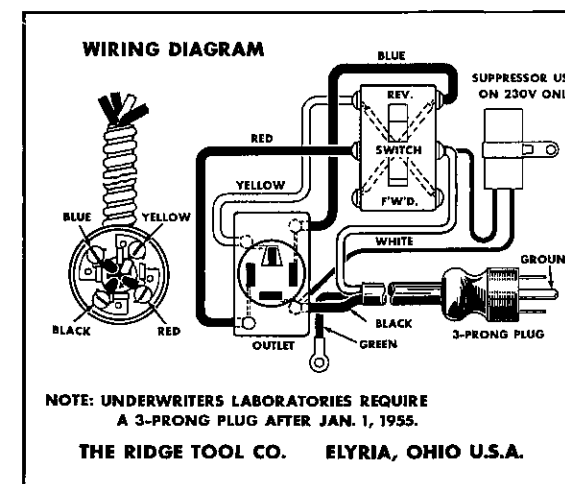
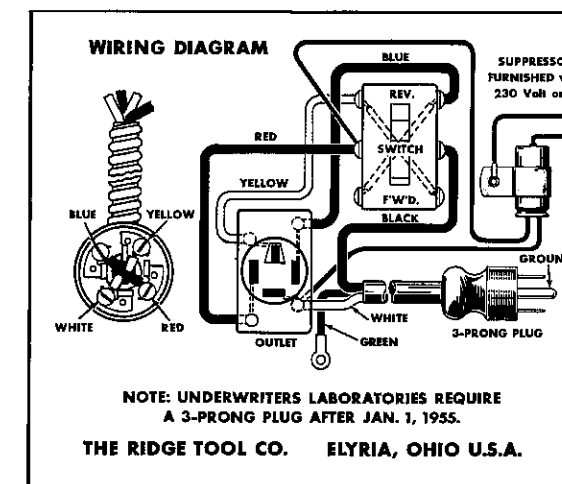

DIAGRAM SERIAL No. 43101 and UP



The Ridge Tool Co. Elyria, Ohio, U.S.A.

Full Lifetime Warranty

All RIDGID Power Equipment and Hand Tools are warranted against defects in workmanship and material. This warranty covers all RIDGID products except electric motors, which are warranted for six months from date of sale. NO OTHER WARRANTY, WRITTEN, OR ORAL APPLIES. No employee, agent, dealer, or other person is authorized to give any warranty on behalf of The Ridge Tool Company. Claims cannot be allowed until the questioned product has been received freight prepaid at our factory or your nearest Authorized Warranty Repair Station for Power Equipment (See accompanying listing). Defective products will be repaired or replaced, at our option, at no charge to you. Such replacement or repair is the exclusive remedy available from Ridge. RIDGE IS NOT LIABLE FOR DAMAGE OF ANY SORT, INCLUDING INCIDENTAL AND CONSEQUENTIAL DAMAGES.

Authorized Warranty Repair Centers — The following RIDGID Warranty Repair Centers are conveniently located to service your needs for parts and repairs on RIDGID and RIDGID/Kollmann Power Tools. They are authorized to conform to our warranty. Please prepay transportation charges when sending a tool in for repair, and include specific instructions stating what you want done. This will prevent delays in returning the repaired tool to you in operating condition.

ALA.-Birmingham 35222, Electric Tool Co., 4801 1st Ave., No.; **ALAS.-Anchorage 99501**, Aero Serv., 203 Post Rd.; **ARIZ.-Phoenix 85014**, Glenn's Tool Serv., 4036 N. 13th Way, **Tucson 85014**, Aero Supply Co., 3409 E. Grant Rd.; **CAL.-Los Angeles 90013**, Midway Tool, 544 So. San Pedro St., **San Francisco 94080**, C.H. Bull Co., 229 Utah Ave.; **COLO.-Denver 80204**, Bartell Tool Serv. Inc., 1110 Acoma St.; **FLA.-Tampa 33609**, Mylee Tool Supply, 2905 W. Kennedy Blvd.; **GA.-Atlanta 30310**, Boggs Supply Inc., 1310 White St. S.W.; **ILL.-McCook 60525**, Recco Tool, Rt. 66 & 53rd St., **Elk Grove Village 60007**, Brock Tool Co., 1475 Louis St.; **IND.-Evansville 47713**, Ram Supply Co. Inc., 1301 W. Franklin St., **Indianapolis 46203**, Anderson Bros. Tool Co., 809 Earhart St.; **KY.-Louisville 40217**, Bailey Machinery & Supply Co. Inc., 1418 So. Shelby St.; **LA.-Metairie, (N.O.) 70002**, Service Tool & Supply Co., 2713 Ridgelake Dr., **New Orleans 70153**, Beerman Precision Machine Works Inc., 2021 Thalia St.; **MASS.-Woburn 01801**, Sutton Electric Tool Serv. Inc., 7 Cedar Dr.; **MICH.-Grand Rapids 49501**, Lakeshore Machinery & Supply Co., 912 Grandville, **Livonia 48151**, Brock Tool, 31090 Industrial Rd., **Oak Park 48237**, Midland Tool, 12771 Capital; **MINN.-Minneapolis 55407**, Kilmartin Tool House Inc., 2845 16th Ave. So., **St. Paul 55101**, Viking Tool Supply, 500 Broadway; **MISS.-Jackson 39212**, Flannigan Electric Co., 328 Oakdale St.; **MO.-Kansas City 64127**, Pipe Tool and Repair Inc., 1421 Wabash Ave.; **N.Y.-Amityville 11701**, Dependable Repair Inc., 18 Ranick Drive W., **Buffalo 14210**, S.S. Electric Repair Shop Inc., 2470 Seneca St., **Harrison 10528**, Pelham Tool Co., 22 Calvert St.; **OKLA.-Oklahoma City 73105**, Midland Equipment Co. Inc., 130 N.E. 31st St., **Tulsa 74120**, Hammond Electric Co., 1510 E. Third St.; **ORE.-Portland 97205**, Karn Repair Serv., 1215 S.W. 16th Ave.; **PA.-Pittsburgh 15203**, Lappe Supply Co., 85 South 24th St.; **S.C.-Columbia 29201**, Mann Electric Co., 2909 Main St.; **TENN.-Nashville 37210**, Contractors Specialties, Inc., 1318 Lenis St.; **TEX.-Dallas 75207**, Brokaw Tool Co. Inc., 2348 Irving Blvd, **Houston 77003**, Serv. Tool & Supply, 1715 Polk, **Lubbock 79401**, MacAustin, Inc., 1701 Texas Ave.; **UT.-Salt Lake City 84115**, Diamond Electric Motor Repair, 1465 So. 300 W.; **WASH.-Lynwood 98036**, Mechanical Maintenance Co., 14626 Highway 99; **WASH. D.C. 20011**-Brock Tool Inc., 5327-29 Georgia Ave. N.W.; **W. VA.-St. Albans 25177**, Smithers Tool Co., 508 4th St.; **WISC.-West Allis 53226**, Blau Plumbing, 12221 W. Fairview.

RIDGID

Pre-Tested Work Saver Tools

Guarantee

All RIDGID Machines, Power Drives and Hand Tools are guaranteed against defects in workmanship and material. This guarantee covers all RIDGID products except electric motors, which are guaranteed for six months from date of sale. NO OTHER WARRANTY, WRITTEN OR ORAL APPLIES. No employee, agent, dealer, or other person is authorized to give any warranty on behalf of The Ridge Tool Company. Claims cannot be allowed until the questioned product has been received freight prepaid at our factory. Defective products will be repaired or replaced, at our option, at no charge to you. Such replacement or repair is the exclusive remedy available from Ridge. RIDGE IS NOT LIABLE FOR DAMAGE OF ANY SORT, INCLUDING INCIDENTAL AND CONSEQUENTIAL DAMAGES.

RIDGID®



Ridge Tool Subsidiary
Emerson Electric Co.