

Model Number HD16400 16 U.S. Gallon (60 Liter) Wet/Dry Vac

Always order by Part Number - Not by Key Number

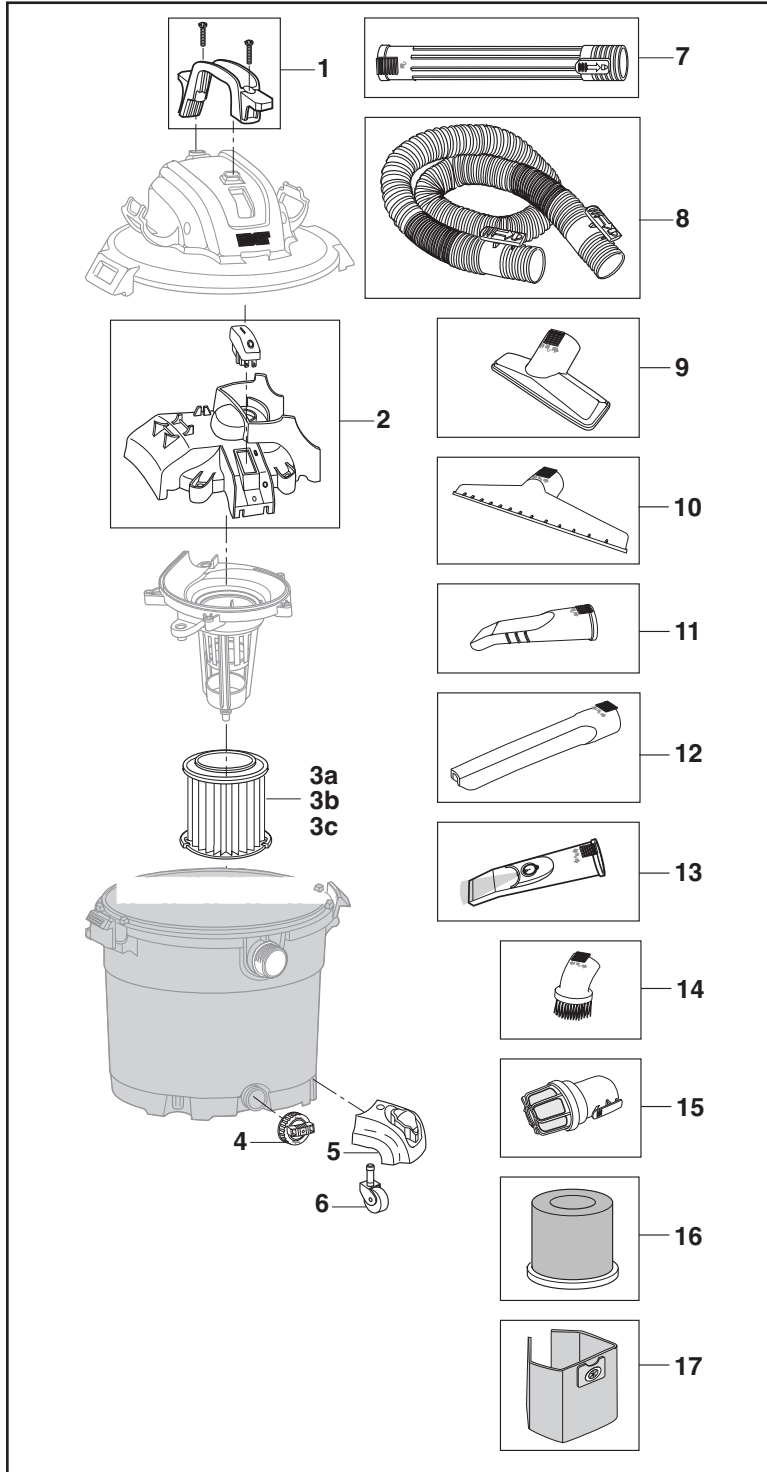

Key Nos.	16 Gallon HD16400 Part Numbers	Description
1	510625	Carry Handle w/Hardware
2	510630	Rocker Switch & Duct Assembly
3a	VF4000	†Qwik Lock™ Filter
3b	VF5000	†Qwik Lock™ Fine Dust Filter
3c	VF6000	†Qwik Lock™ HEPA Media Filter
4	73185	Drain Cap
5	844340	Caster Foot w/Storage
6	73137	Caster (2" Diameter)
7	LA2508	†Extension Wand
8	LA2520	†Tug-A-Long Positive Locking Hose w/Dual-Flex™
9	LA2509	†Utility Nozzle (2-1/2")
10	LA2510	†Wet Nozzle (2-1/2")
11	LA2503	†Car Nozzle (2-1/2")
12	LA2502	†Crevice Tool (2-1/2")
13	LA2539	†LED Lighted Car Nozzle (2-1/2")
14	LA2501	†Dusting Brush (2-1/2")
15	VT2525	† Muffler Diffuser (2-1/2")
16	VF7000	†Wet Filter
17	VF3502	†Size A - Dust Collection Bag

† These replacement parts are also available where you purchased your Vac.