

Pre-Cut Tube To Correct Length

1. Add all blueprint center to center dimensions for the total tube length. Mark tube at this total length. (Figure 1)
2. Because most blueprints are dimensioned as though all corners were square, less tube is actually required than the total of the blueprint dimensions. Therefore, **REDUCE** the total length by the number of bends, using the Gain Scales on the Swinging Arm. (See Figure 2)
3. Reduce the measured length of tube from Step 1 by one graduation for each 90° bend using the scale marked "90° Gain". Reduce Length of tube by one graduation for each 45° bend using the scale marked "45° Gain". (See Figure 2) Mark tube and cut.

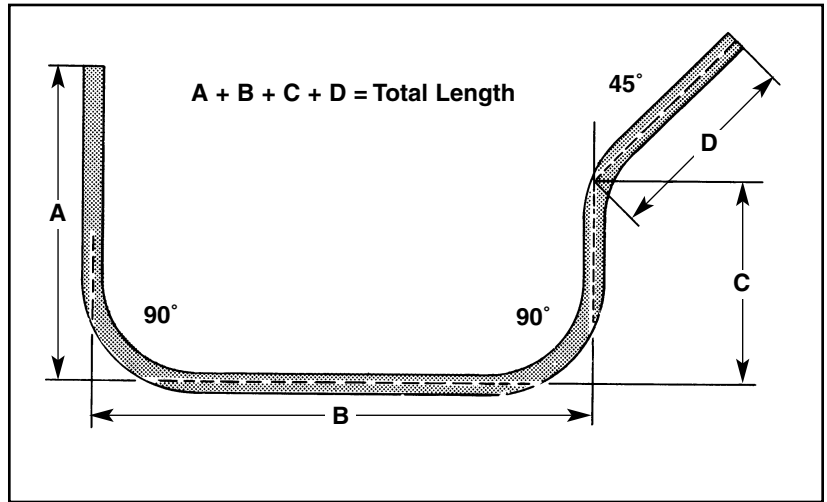

Figure 1

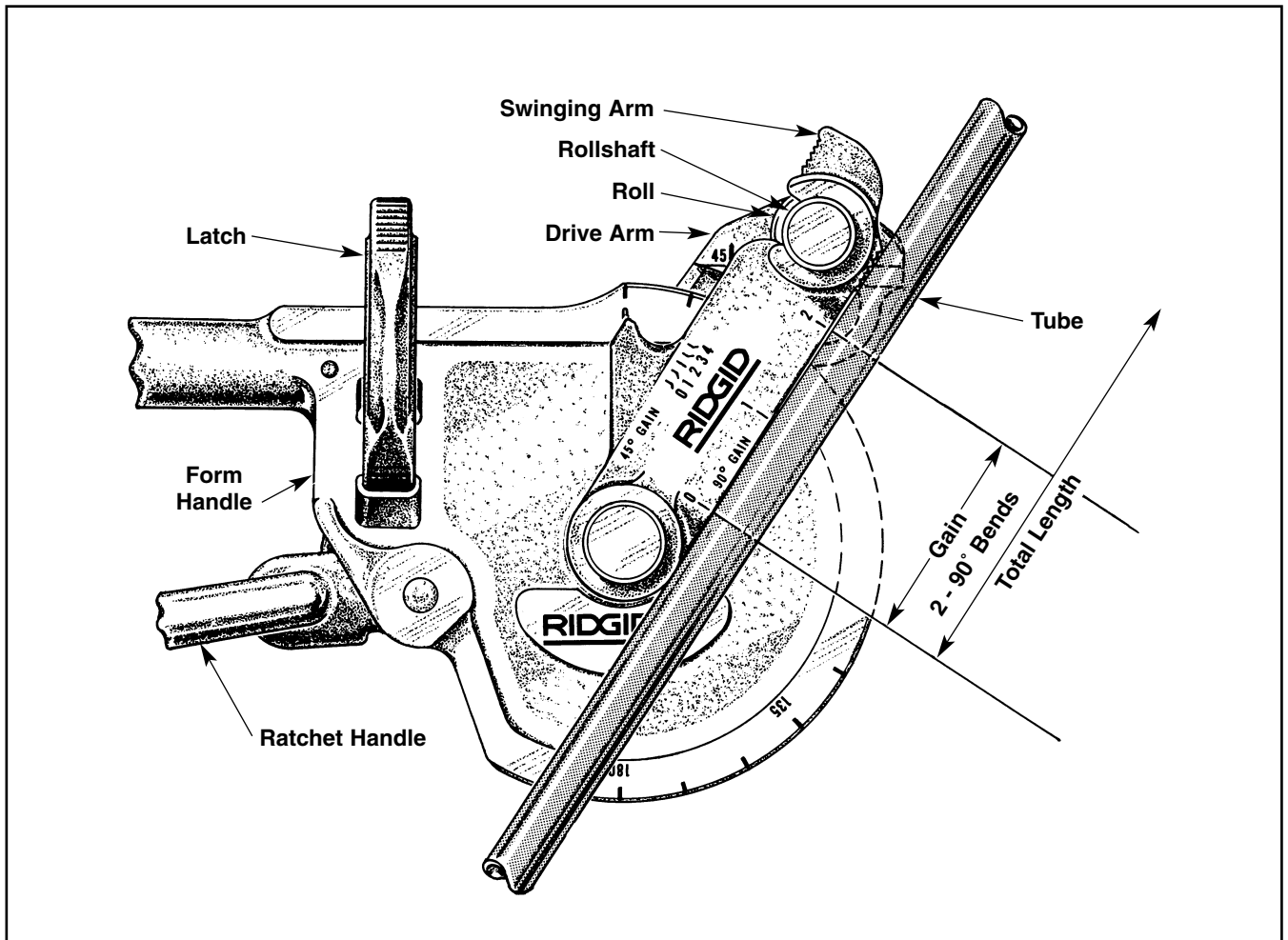

Figure 2

90° Bends

4. For first bend, measure from end of tube and mark at blueprint dimension. (Figure 3)
5. Raise Latch. Bring handles together to release Drive Arm. Swing Drive Arm counter clockwise until it stops. Move Swinging Arm to clear opening between Form Handle & Roll.
6. Position tube in bender. (Figure 4a) If the end from which you measured is in the Form Handle, the measured mark should be directly under the 90° mark on the Drive Arm. (Figure 4a) If, however, the end from which you measured is to the right (Not in the Form Handle), set the mark on the tube directly under the "R" on the Drive Arm. (Figure 4b)
7. Close Latch over tube and Swinging Arm over Roll Shaft.
8. To Ratchet - Pull Ratchet Handle away from Form Handle. After each pull, Drive Arm will remain locked due to the Holding pawl. Actuate Ratchet Handle until pointer on Swinging Arm is at 90°. Because tubing has a slight springback action, it may be necessary to over bend slightly to allow tube to spring back to 90°.
9. To release Bender, follow Step 5.
10. If more than one bend is required, measure from center line of the preceding bent leg and mark tube to blueprint dimension (See Figure 5). Position tube in bender as outlined in Step 6.
11. For convenience, the Form Handle Clamping Pad may be held in a vise.

45° Bends

12. For first bend, measure from end of tube and mark at blueprint dimension.
13. Position tube in bender, as illustrated in Figure 4 a-b. When making a 45° bend, the end from which you measured and marked the tube may be either in the Form Handle or to the right (Not in the Form Handle). In either case, the mark on the tube should be under the 45° mark on the Drive Arm.
14. Close Latch over tube. Move Swinging Arm to engage Roll Shaft.
15. To Bend - Follow Step 8 until pointer on Swinging Arm is at 45°.

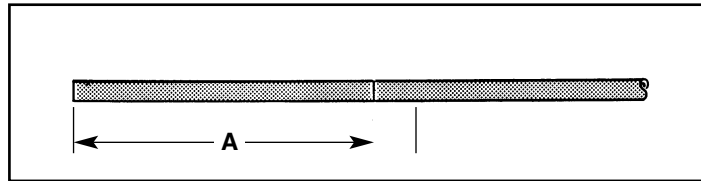

Figure 3

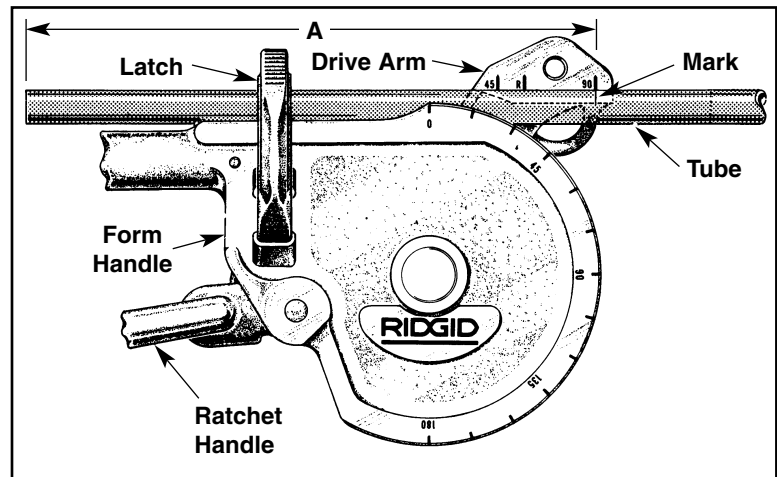

Figure 4a

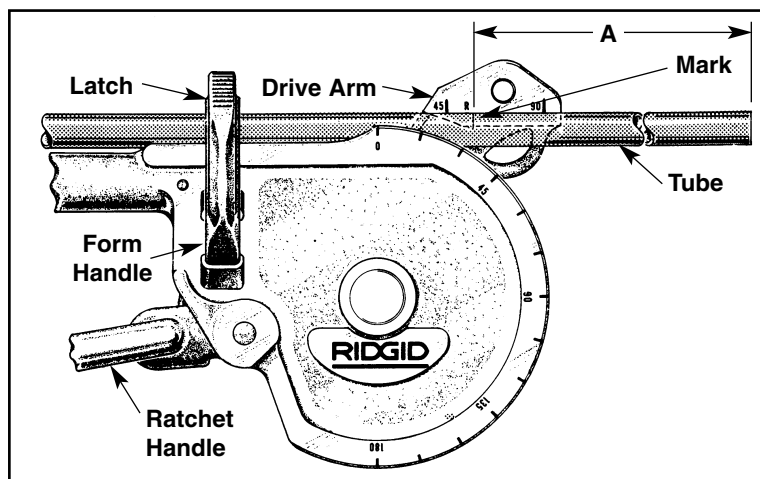

Figure 4b

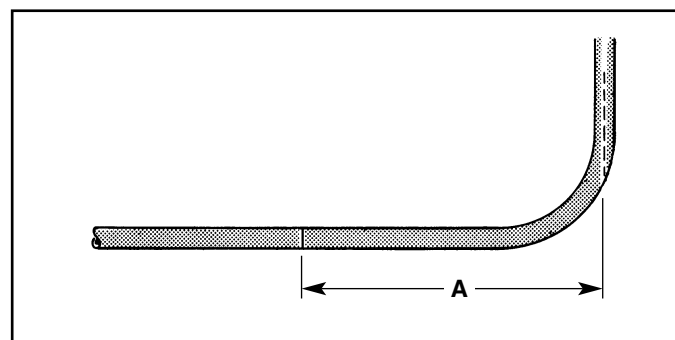

Figure 5