

## Important Product Safety Notice

These instructions describe the steps for retrofitting RIDGID® ProPress XL and R2 Rings (2½", 3" and 4" sizes) with straps as discussed in the product recall notice dated August 31, 2007.

These Retrofit Instructions do *not* apply to rings marked "ProPress XL-C".

### ⚠ WARNING

**Wear safety glasses to reduce risk of injury during assembly.**

**It is important to follow all instructions. Improper assembly may result in personal injury, death or property damage.**

### Required Time

Retrofitting a set of three rings takes approximately five minutes.

### Required Tools

- External retaining ring pliers
- Flat blade screw driver
- Hammer
- Large adjustable pliers or punch

1. Confirm that all retrofit parts are present in kit. Retrofit kit contents includes three metal straps (two long and one short), three new pivot pins, and six retaining rings. If any parts are missing or incorrect, contact Ridge Tool Technical Services. One kit retrofits one 2½" - 4" ring set.
2. Remove retaining ring from both sides of the pivot pin on the ProPress XL/R2 ring with retaining ring pliers. **Do not yet remove the pivot pin.**
3. Choose correct strap for the ring. The kit includes three straps. The two long straps fit both the 3" and 4" ring. The short strap with the hole in it will only fit the 2½" ring. A comparison of the straps is shown in *Figure 1*.

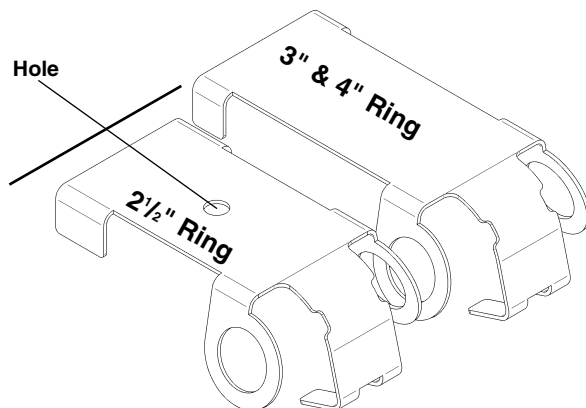

Figure 1 – Long 3"/4" strap and shorter 2½" strap

4. Place the metal strap around the hinge area of the ring. Work the strap around the pin on both sides of the ring and over the inner tabs of the hinge. In *Figure 2*, a screwdriver is used to work the strap over the pivot pin.
5. Place a new retaining ring on the new pivot pin using retaining ring pliers.

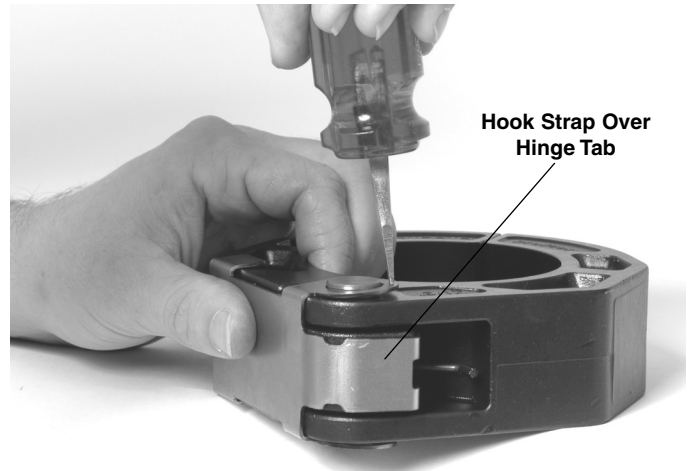

Figure 2 – Working the strap onto the ring

6. The pivot pin in the ProPress XL/R2 rings retains the spring that holds the ring closed. Drive out old pivot pin by placing the side of the new pin with the retaining ring attached (previous step) is away from the ring. Use a hammer to drive the new pin into the ring as shown in *Figure 3*. **Attempting to remove the old pin without pushing the new pin into place at the same time may allow the spring to eject from the ring and cause injury.**

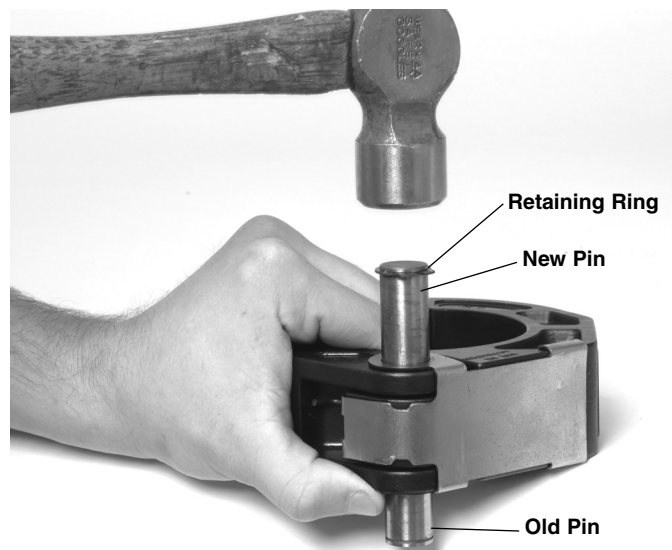

Figure 3 – Using the new pin to drive out the old pin.

7. Place a new retaining ring on the side of the pin that does not already have one. When installing the retaining ring, it may be necessary to push on the strap with a flat bladed screwdriver to allow enough clearance for the retaining ring, as shown in *Figure 4*.



**Figure 4 – Installing the retaining rings.**

8. Using either a large adjustable pliers or a hammer and punch, bend the tabs on the strap around the ring so that the strap is tightly secured to the ring. *Figure 5* shows how to bend the tabs with a pliers. When finished, the tabs should look like those in *Figure 6*. If they are too loose or if there is a large gap between the ring and the strap, continue to fold the tab tighter until the strap conforms to the shape of the ring.



**Figure 5 – Using an adjustable pliers to bend the tabs.**

9. Fill out enclosed postage prepaid verification card and mail.



**Figure 6 – Strap with tabs bent correctly.**

If you have any questions regarding these instructions, contact:

Ridge Tool Company  
Technical Service Department  
400 Clark Street  
Elyria, OH 44035-6001  
Tel: (800) 519-3456  
Email: [TechServices@ridgid.com](mailto:TechServices@ridgid.com)